

Liquids to Value



Hygienic GEA Tuchenhagen®-VARIFLOW Centrifugal Pumps

TP/TPS series

Economical – sustainable – service-oriented

Made by GEA Tuchenhagen



GEA Tuchenhausen products meet the growing demand for environmentally compatible components. Our basis for this is a future-oriented corporate and product concept committed to economic efficiency, sustainability and service-orientation.

Economically efficient

The current generation of GEA Tuchenhausen®-VARIFLOW pumps provide users with considerable cost savings.

Modern GEA Tuchenhausen components provide special advantages that enable superior economic performance and help the user to gain operative advantages at reduced costs. Sensibly rated high-efficiency motors in every dimension needed are available to cover the typical requirements of the markets. They enable that energy consumption is kept as low as possible, which means a positive impact on your profitability.

Carefully designed flow paths free from dead corners enable optimum utilization of the conveying energy. The product is conveyed evenly and gently, resulting in a higher product quality, which provides the user with improved processing options and distribution potentials. The cleaning requirement is considerably reduced as far as time, water and resources are concerned, with a positive impact on production planning and cost accounting.



Economically

- High product quality
- Reduced consumption of energy, water and cleaning media
- Saves time in maintenance and cleaning



Sustainable

Lower consumption of energy, water and chemicals means less load on environment and climate. For GEA Tuchenhagen users, the future success of their business, and the continuing acceptance of their production site this aspect will become more and more important.

On many markets, ecological criteria and the quality seals introduced for them increasingly determine retail assortment planning and what consumers will buy. Users of GEA Tuchenhagen products will not only be at an advantage due to production processes which have proven to be environmentally friendly but also as a result of their maximum hygiene and care when processing their products.

This helps users to fulfil their own commitment to sustainable working methods – the best way towards a secure future!

Sustainable

- Less load on climate and environment
- Environmental orientation production methods
- Maximum hygiene and care in product processing

Service-oriented

Plant designers and engineering companies appreciate the benefits offered by GEA Tuchenhagen: they cannot only profit from a range of highly efficient products but also use the individually tailored engineering support available from GEA Tuchenhagen.

Maintenance service offers which protect your investment enable that the necessary service work on GEA Tuchenhagen components can be carried out with just minor interruptions in production processes individually tailored to the customer's requirements.

Service-orientated

- Individual engineering support
- Life cycle cost calculations
- Minor production interruptions
- Tailor made service concepts

GEA Tuchenhagen®-VARIFLOW Centrifugal Pumps

The GEA Tuchenhagen®-VARIFLOW Centrifugal Pump TP is designed for pumping demanding media up to a viscosity of 1,000 mPas. Low flow velocities and gentle discharge of media through the spiral housing ensure extremely gentle product handling and high efficiency.

10 pump sizes with a capacity range of up to 210 m³/h and pump heads of up to 90 m w.c. are available, finely tuned to the task at hand.

The spiral housing for the TP series is made of cold-rolled steel. This material has an excellent surface quality, which is essential for optimum cleaning in CIP/SIP processes. Wall thicknesses of 6 mm provide high strength for critical piping configurations and high inlet pressures.



Applications

- **Breweries**
Beer, wort, yeast, water, CIP solutions
- **Dairies**
Milk, cream, yoghurt, whey, brine, CIP solutions
- **Food**
Oils, sauces, stock, brine, flavours, ice-cream mix, CIP solutions
- **Pharmaceuticals/Cosmetics**
Ultra-pure water, extracts, emulsions, WFI water, distillates
- **Fields of applications TP**
Conveying, circulation, pressure boosting, filling lines, filling, emptying, filtration, evaporation, cleaning
- **Fields of applications TPS**
CIP solutions, tank emptying, gas conveying

GEA Tuchenhagen®-VARIFLOW Centrifugal Pumps

By combining the existing TP series with an upstream screw rotor stage a new generation of hygienic self-priming centrifugal pumps has been created.

The GEA Tuchenhagen®-VARIFLOW Centrifugal Pump

TPS is a self-priming pump for viscosities of up to 500 mPas. The pump is used for CIP return applications, for emptying tanks as well as for conveying products containing gas.

The TPS is characterized by a low sound power level, highest efficiency and excellent cleaning properties. The TPS series also permits evacuation of pipes on the suction side – so that just one pump is required for CIP return and product conveying!



Technical benefits

- Operating pressure max. 16 bar
- Low NPSH value avoids early cavitation to the pump
- Optimized hydraulic efficiency
- The pumping characteristic can be adapted to the requirements of your system by speed control or impeller trimming
- Optimal SIP/CIP characteristics

Constructive characteristics

- Open impeller design
- All parts stainless steel, wetted components made of 1.4404 or 1.4409 (AISI 316L)
- Surface roughnesses of $Ra \leq 0.8 \mu\text{m}$ can be achieved by mechanical treatment of the surface (higher surface qualities on request)
- Driven by standard motors, design type IM B35, according to IEC
- Wearing parts identical for TP and TPS
- Use of the VARIVENT® sealing principle

Special Features

- Gentle product handling
- Standard connection: DIN 11864 Aseptic flange
- Low wear part stock requirement
- Acceptance test certification 3.1 (optional)
- EHEDG approved and certified
- Optimal cleaning characteristics
- Low noise operation
- Sealings comply to FDA and USP Class IV
- TPS: less sensitive to particles in the product
- No bearing flange needed due to low axial forces (pump shaft force-fit connected to motor shaft)

GEA Tuchenhagen®-VARIFLOW Centrifugal Pumps, Types TP & TPS

Program Overview



		non self-priming				
		TP 1020	TP 1540	TP 2030	TP 2050	TP 2575
2-pole, 50 Hz	max. flow rate [m³/h]	20	35	36	36	40
	max. pump head [m]	24	42	36	60	85
	Motor rating kW, 2-pole	1,1 - 5,5	3,0 - 15,0	1,5 - 11,0	3,0 - 15,0	5,5 - 30,0
4-pole, 50 Hz	max. flow rate [m³/h]	10	19	19	19	20
	max. pump head [m]	6	11	9	15	21
	Motor rating kW, 4-pole	0,75 - 3,0	0,75 - 3,0	0,75 - 5,5	0,75 - 4,0	3,0 - 7,5
2-pole, 60 Hz	max. flow rate [m³/h]	24	44	44	42	48
	max. pump head [m]	34	62	52	85	130
	Motor rating kW, 2-pole	1,25 - 6,3	3,6 - 17	1,8 - 12,5	3,6 - 17	6,3 - 34,5
4-pole, 60 Hz	max. flow rate [m³/h]	11	22	23	21	22
	max. pump head [m]	8	15,5	13	21	31
	Motor rating kW, 4-pole	0,9 - 3,6	0,9 - 3,6	0,9 - 6,3	0,9 - 4,5	3,6 - 8,6
Impeller diameter		80 - 130	130 - 180	110 - 160	160 - 210	200 - 250
min. NPSH (2.900 min ⁻¹)		1,0m	1,0m	1,0m	1,0m	1,0m
max. viscosity mPas		1.000	1.000	1.000	1.000	1.000

GEA Tuchenhagen®-VARIFLOW Centrifugal Pumps, Types TP & TPS



non self-priming					self-priming	
TP 3050	TP 5060	TP 7060	TP 8080	TP 16040	TPS 2030	TPS 3050
75	75	110	120	210	32	55
65	75	74	90	49	37	64
3,0 - 22,0	5,5 - 30,0	7,5 - 30,0	11,0 - 37,0	11,0 - 45	2,2 - 11,0	3,0 - 22,0
36	40	55	65	100	n.a.	n.a.
16	17	19	23	12	n.a.	n.a.
0,75 - 7,5	2,2 - 7,5	2,2 - 7,5	4,0 - 7,5	3,0 - 7,5	n.a.	n.a.
85	80	120	125	240	36	69
95	110	105	130	70	52	95
3,6 - 25,0	6,3 - 25,0	11,0 - 34,5	17 - 42,5	17 - 45,0	2,5 - 12,5	3,6 - 25,0
42	45	65	75	120	n.a.	n.a.
24	24	27	34	17	n.a.	n.a.
0,9 - 8,6	2,5 - 8,6	3,6 - 8,6	4,5 - 8,6	3,6 - 8,6	n.a.	n.a.
140 - 210	175 - 225	175 - 225	180 - 250	160 - 200	110 - 160	140 - 210
0,8m	0,9m	1,0m	1,2m	3,8m	0,8m	0,8m
1.000	1.000	1.000	1.000	1.000	500	500

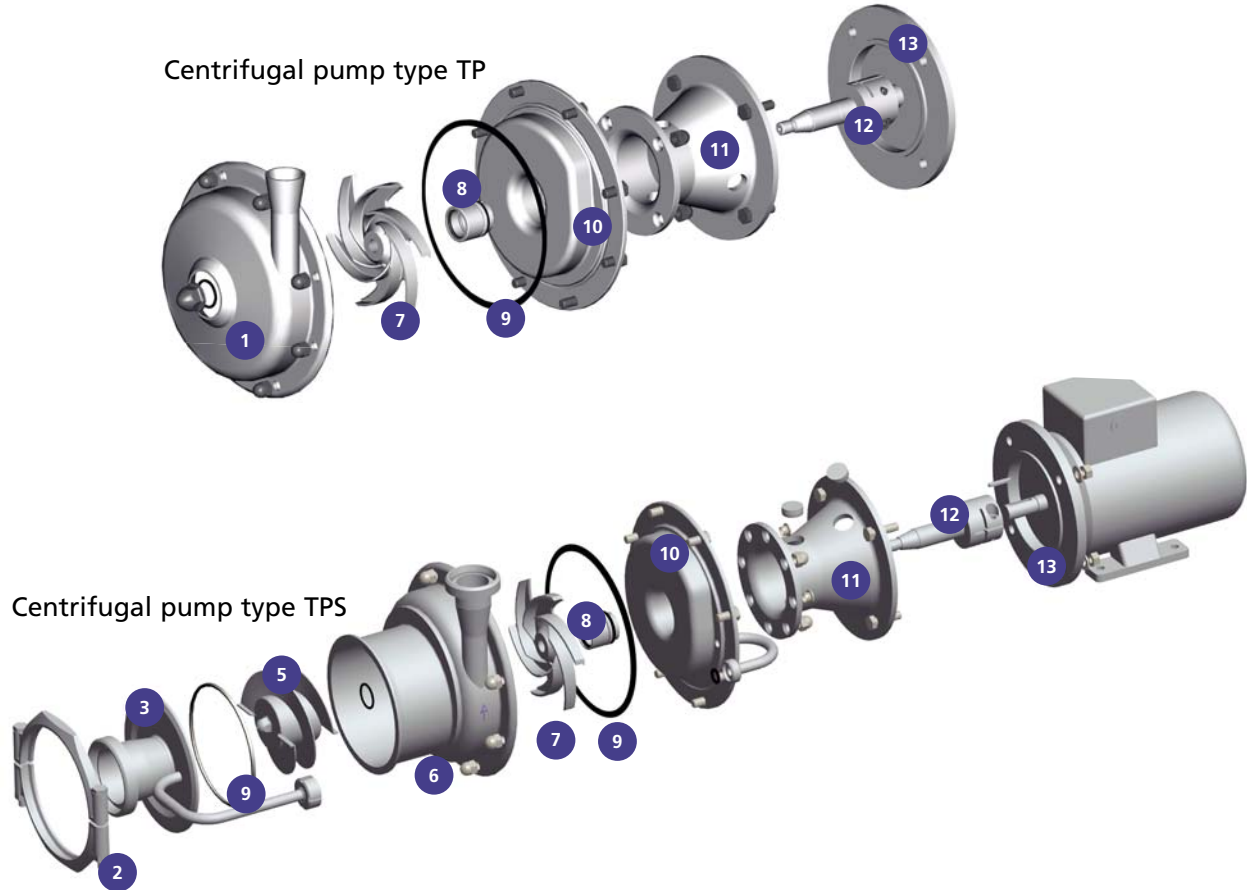

Centrifugal pump type TP

- 1 Pump cover

Centrifugal pump type TPS

- 2 Clamp connection
- 3 Rotor housing cover
- 4 Recirculation pipe
- 5 Rotor
- 6 Rotor housing

Centrifugal pump type TP/TPS

- 7 Impeller
- 8 Mechanical seal
- 9 Sealing according to VARIVENT® principle
- 10 Pump housing
- 11 One-piece lantern
- 12 Pump shaft without key
- 13 Motor

Connection fittings

- Aseptic union to DIN 11864-1 (standard)
- Aseptic flanges to DIN 11864-2
- Metric and Inch OD diameters
- VARIVENT® flange connection, type tested and TÜV approved
- Threaded joint according to DIN 11851
- Other marketable connections according to BS, SMS, RJT, Tri-Clamp

Sealing of TP/TPS centrifugal pumps according to the VARIVENT® principle

The special groove enables the seal is kept reliably in place at all times. The shape of the groove is based on FEM analyses. The metallic stop allows a defined compression of the seal, ensuring gap-free sealing against the product chamber without dead corners.

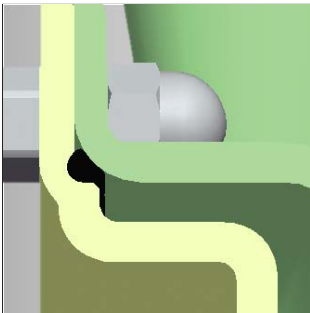

O-ring sealing between pump housing and cover

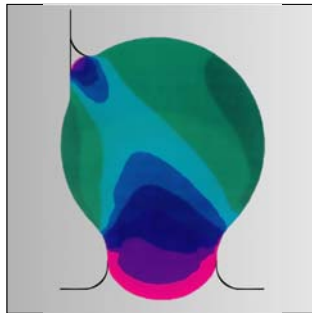

FEM showing the seal ring in operating mode



Inducer for TP series



Drainvalve Type VTP controlled pneumatically or operated manually, for complete draining of the pump housing without dead pockets

Mechanical seals for optimum CIP/SIP capability

An aseptic mechanical seal is used with a support spring outside the product room. No special tools and dismantling of the pipe are required for maintenance.

- Mechanical seal unit can be removed from the front
- Flushing unit easy to retrofit
- Pump shaft protected by wear sleeve
- Only two mechanical seal sizes for the entire pump series
- Seal face material options: carbon/silicon carbide (standard), silicon carbide/silicon carbide, carbon/stainless steel, various elastomers with FDA approval (EPDM, FKM)

Design variants

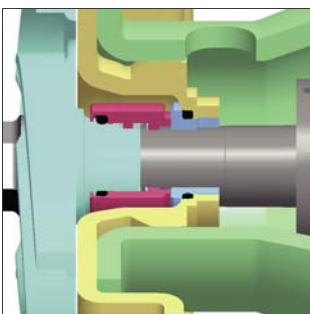

Single mechanical seal (standard)

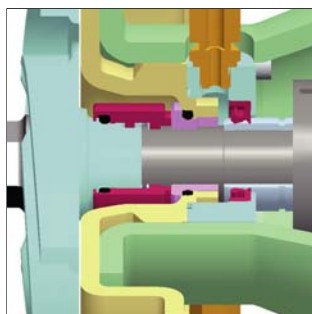

Single mechanical seal, flushed (quench)

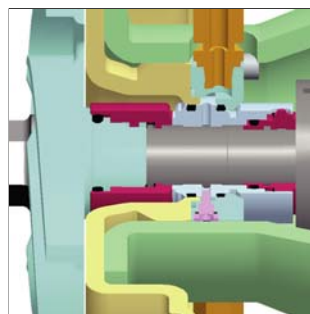

Double mechanical seal

Pump performance curves type TP, $n = 2.900 \text{ min}^{-1}$

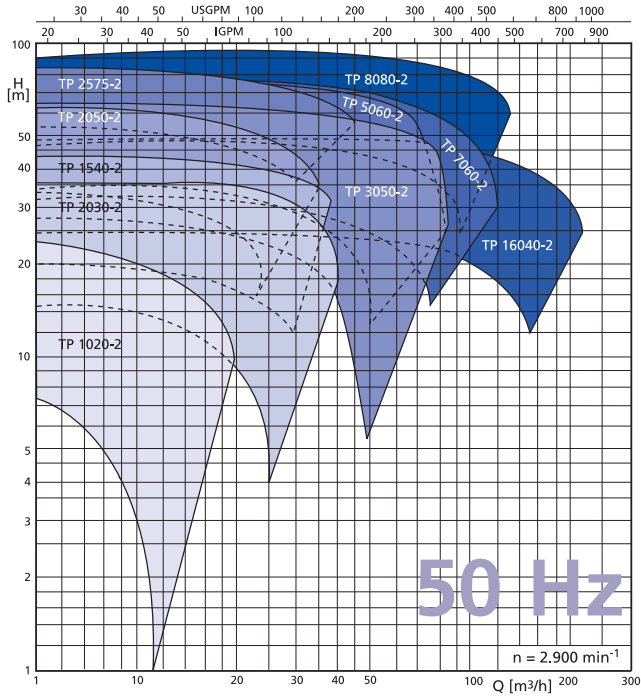

Pump performance curves type TP, $n = 1.450 \text{ min}^{-1}$

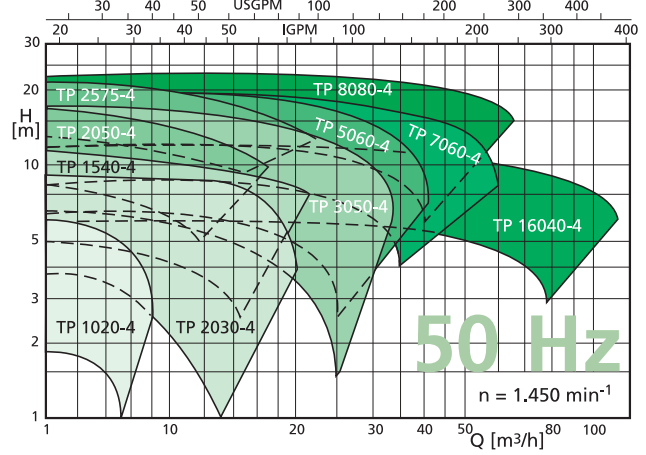

Pump performance curves type TP, $n = 3.500 \text{ min}^{-1}$

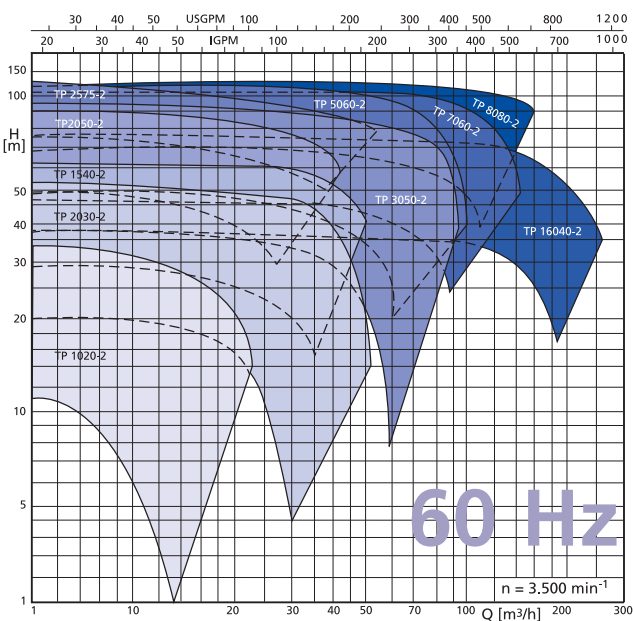

Pump performance curves type TP, $n = 1.750 \text{ min}^{-1}$

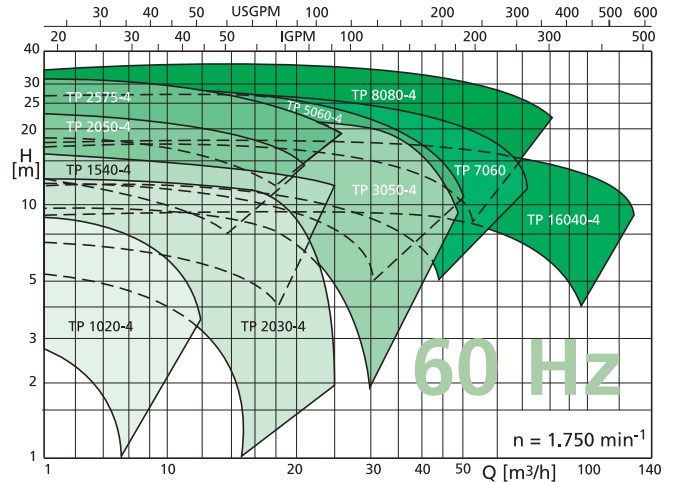

Pump performance curves type TPS, n = 2.900 min⁻¹

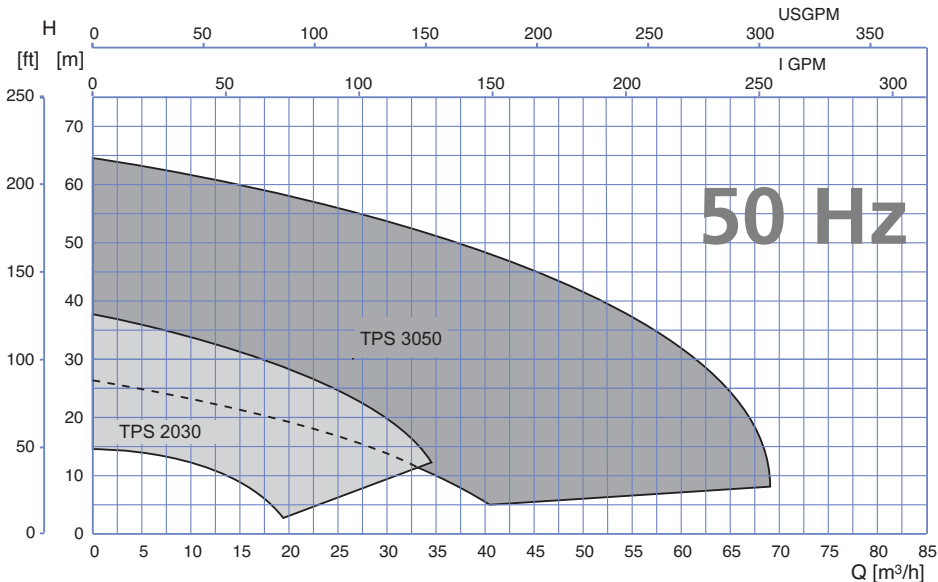

Pump performance curves type TPS, n = 3.500 min⁻¹

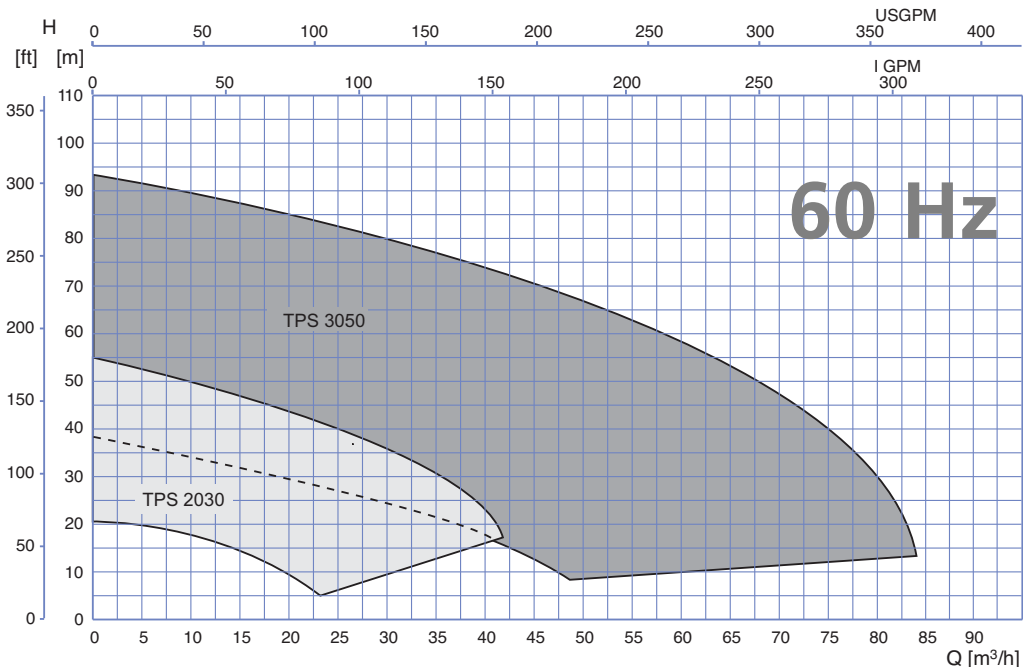

Independent institutes have proven the cleaning ability for media conveying in hygienic processes.





GEA Mechanical Equipment

GEA Tuchenhagen GmbH

Am Industriepark 2-10, 21514 Büchen, Germany

Phone +49-4155 49-0, Fax +49-4155 49-2423

sales.geatuchenhagen@geagroup.com, www.tuchenhagen.com